

ASSEMBLY INSTRUCTION

MODEL NO.:AO50BLL (black)/AO50GRL (Grey)
AO50TNL (Tan)/AO50CHF



GENERAL BEST PRACTICES FOR ASSEMBLY

Read all instructions before starting.

Separate all parts before starting.

Clear a flat covered space to assemble.

If parts are missing, broken, damaged or worn, stop using the product until all repairs are made.

Always keep children under close supervision while they are using or around this product. Never leave children unattended.

This product is intended for domestic, indoor use only, not intended for commercial use.

WARNINGS:

Do not stand or step on this chair.

Do not rock back and forth on this chair. Use for seating only one person at one time.

Do not use this product unless all bolts and screws are firmly secured.

Do not tighten screws before all screws are in the right place.

Do not exceed maximum weight capacity of 225lbs (102kg.)

Some parts may contain sharp edges.

Wear protective gloves if necessary.



NOTE:

To avoid damage, ensure screws are hand tightened. **DO NOT USE POWER TOOLS TO ASSEMBLE YOUR UNIT.**



1 person

PARTS LIST



AX 5

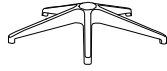

B X 1



CX 1



DX 1

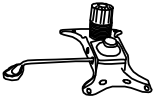

EX 1



FX 1

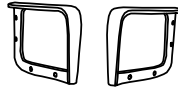

G X 1(L&R)



HX 1

HARDWARE



IX 4

M8*20mm



JX 8

M6*25mm

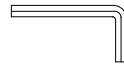

KX 1



LX 4

STEP 1

- 1) Insert the five castors [A] into the base as shown in the diagram, make sure all castors are firmly inserted.
- 2) Insert the gas lift [C] into the center of star base [B] as bellow step.
- 3) Insert the gas lift [C] as shown in the diagram, and place telescopic cover [D] over the gas lift [C].

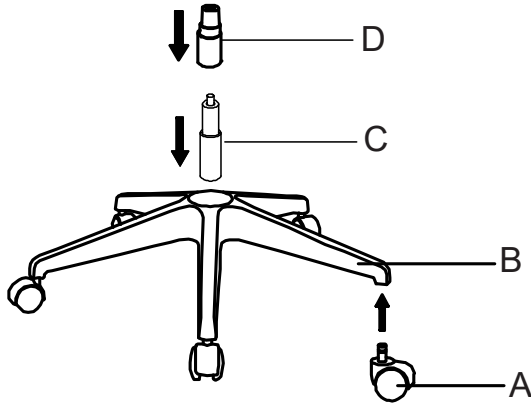

STEP 2

Attach the seat plate [E] to the bottom of the seat cushion [F] with screws [I] by using allen wrench [K] as shown in the diagram. Do not full tighten the screws until all screws are in place.

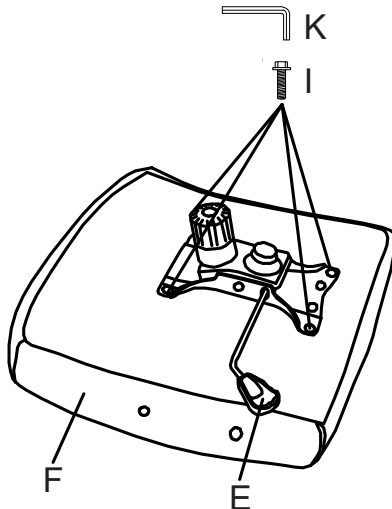

STEP 3

Place the assembled seat onto the gas lift [C], making sure the gas lift [C] top is inserted into the hole on mechanism [E] as shown.

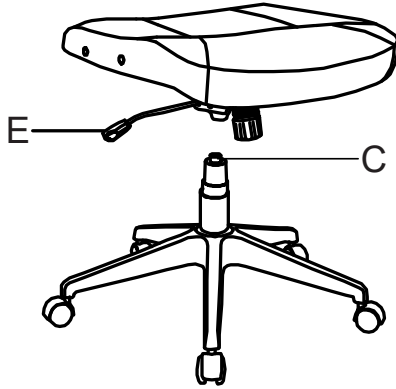

STEP 4

Attach the armrests [G] to the each side of seat cushion [F] with screws [J] using allen wrench [K] as shown in the diagram. Do not full tighten the screws until all screws are in place.

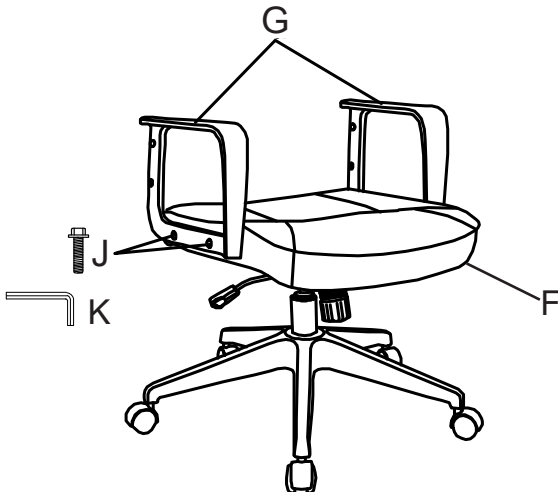

STEP 5

Place backrest [H] between the two armrests to make sure that the upper holes on both parts are aligned as bellow diagram shown. Secure with screws [J] and lightly turn the screws with allen wrench [K].



STEP 6

1) Tilt the backrest [H] upright until the holes at the bottom of both parts are aligned and tighten all screws [J] with allen wrench [K].

2) Cover the screws with plastic caps [L], making sure they fit tightly.

